

# Avery Weigh-Tronix

PLATINUM DISTRIBUTOR



888-236-5650

sales@bsiscales.com

www.bsiscales.com

# QTLTSC

## CLASS III

### FORKLIFT SCALE SYSTEM

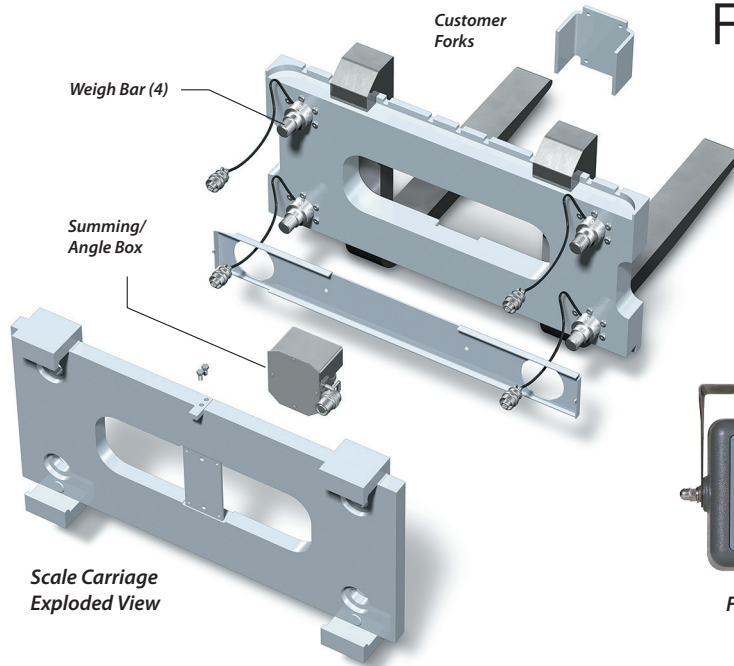

*Technical Specification*



FLI 225

## DESCRIPTION

### General

The Avery Weigh-Tronix QTLTSC Forklift Scale System is a, legal-for-trade weighing solution. The system includes a durable, front-mounted digital scale carriage with Weigh Bar® electronic weight sensors and viewing ports. The system allows operators to easily and quickly capture legal-for-trade weight data en route, without extra steps.

### Seamless Compatibility

Simply attach the QTLTSC scale carriage to an existing Class III cleat-type forklift carriage and mount the FLI 225 instrument in a convenient driver location. This system allows seamless integration of weighing and data management into your operations without adding any extra steps or route changes.

### Robust Design

The forklift scale carriage is comprised of two metal plates coupled together by four high capacity Weigh Bars.

- › Front loading safety factor of 29.5:1
- › Normal load safety factor of 7.5:1
- › Overload with no damage of 200%

The instrumentation is designed exclusively for the forklift vehicle. It incorporates design technologies to withstand the environmental and warehouse jolts common in forklift applications.

### Highly Accurate

The Avery Weigh-Tronix QTLTSC system monitors the orientation of the scale and maintains accurate weight readings even if the forklift is on unlevel ground, the mast is tilted, or the pallet load is off-center. The forklift drivers are not required to jockey the mast or the position of the load on the scale.

The accurate weighing performance of the QTLTSC has been validated by NCWM (National Conference on Weights and Measures) to weigh legal-for-trade even when tilted:

- › 3 degrees side to side (5% grade)
- › 8 degrees forward to back

This electronic scale design has no mechanical flexures or springs to influence the weighing performance.

### Data Management

The FLI 225 instrument provides a simple, no-nonsense solution through classic or enhanced operation for capturing weight and supplying it to a peripheral device.

**SCALE CARRIAGE**

Front and Back Plates Yield Strength	100,000 psi
Weigh Bar® Fasteners Yield Strength	160,000 psi
Weigh Bar Tensioners Yield Strength	130,000 psi
Mounting Hooks Yield Strength	59,000 psi
Scale Centering Pin Yield Strength	89,000 psi
Safety Factors	29.5:1 front loading, 7.5:1 normal loading, 300% no damage overloading
Weight Sensors	Four Avery Weigh-Tronix 2500 LB or 6000 LB Weigh Bars direct coupled, no flexures
Weight Summing	Assembly encapsulated
Cover Plates	Weigh Bar cabling protection
Wired Interface	Coiled cable extending to 20'
Finish	High grade powder paint

**WEIGH BAR**

Type	LTT 2.5k weight sensors (4) NTEP CC# 95-093, 5,000 LB. LTT 6k weight sensors (4) NTEP CC# 95-093, 10,000 LB
Metal Properties	AISI 4340 steel yield strength 140,000 psi
Zero Balance	± 0.10 mv/v
Non-Linearity Maximum	0.3% of rated output
Hysteresis Maximum	0.03% of rated output
Temperature Effect on Output	± 0.0025% ° C of rated output (-10 to +40° C)
Temperature Effect on Zero Balance	± 1.70 x 10 <sup>-7</sup> volts per volt 5° C (-10 to +40° C)
Safe Overload Rating	150% of capacity

**WEIGHT SUMMING AND ANGLE DETECTION ASSEMBLY**

Enclosure	Metal enclosure, circuitry encapsulated
Environment	Legal 14° to 104° F (-10° to +40° C), industrial -40° to +65° C
Angle Sensors	0.1 degree accuracy from 0-10 degrees
Angle Sensor Temperature Coefficient	0.008%/° C

**SYSTEM**

Lifting Capacity	Reduced 12-14%
------------------	----------------

**APPROVALS**

NCWM Certificate of Conformance 95-126  
Accuracy Class III, 5000 x 5 LB; 10,000 x 10 LB  
Compatible with ITA Class III, 20" high cleat type carriage  
FCC part 15B  
ECTAC UK 2862  
CE

Weigh Bar® is a registered trademark of Avery Weigh-Tronix, LLC

**FLI 225 INSTRUMENTS**

Type	FLI 225 instrument NTEP CC# 07-091, category 3
Power Input	9 to 36 vdc, 3.5 Amp, Inactive stand by mode
Display	FLI 225 - High contrast backlit transfective LCD dot matrix. Custom designed font 3/4" high digits. Classic, Classic with Accumulation and Expanded Modes
Operational Keys	FLI 225 - On/Off, Zero, Print, Select, Tare, F1-F4
Operational Images	FLI 225 - Weight, LB/KG, Motion, Center of Zero, Weigh mode and Operator status messages
Angle Compensation	Detects and automatically compensates for out of level accurate weighing
Communication Ports	FLI 225 - Two RS 232 serial ports
Operating Environment	Legal 14° to 104° F (-10° to +40° C), industrial -20° to +60° C
Enclosure	FLI 225 - Composite with tilt and swivel brackets, designed to IP65
Dimension	FLI 225 - 8.14"W x 5.19"H x 4.03"D includes mounting bracket
Weight	FLI 225 - 4 LB / 1.8 KG
Options	FLI 225 - FLP 100 power conditioner 24 to 72 vdc and RM 100 bt (2.0)